

Perspective View

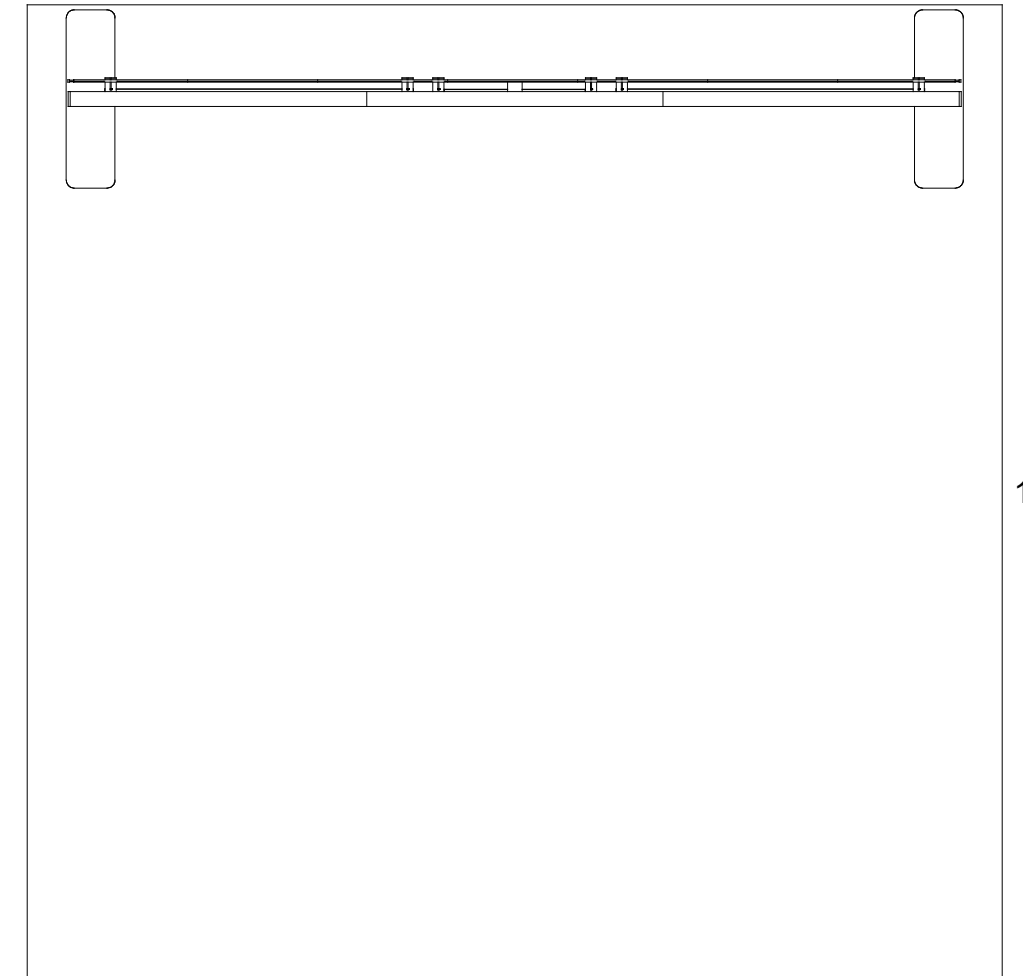

10'

Plan View

10'

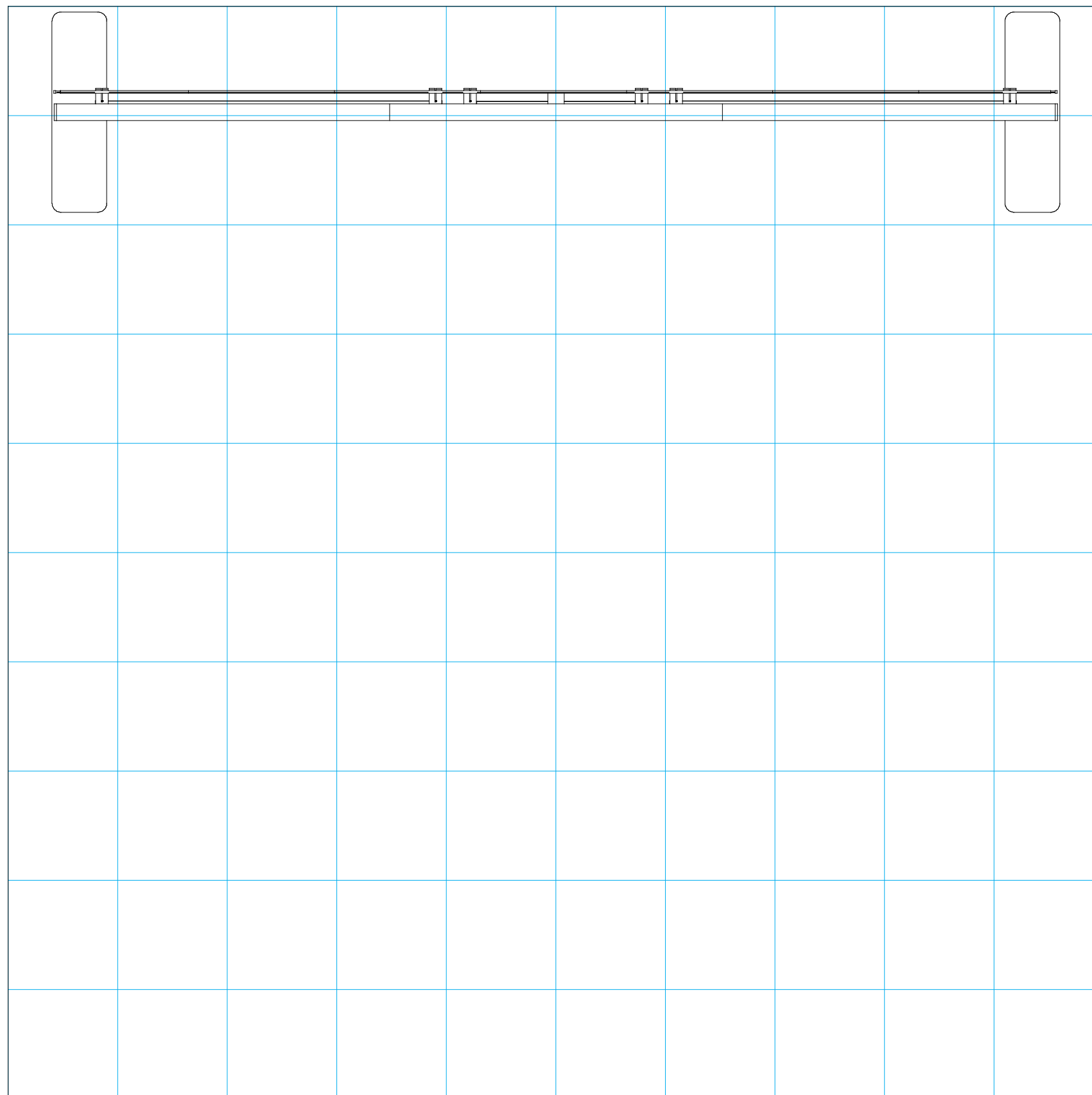

= 1 sq ft

## General Setup Instructions

- Read entire setup instruction manual prior to unpacking parts and pieces.
- The setup instructions are created specifically for this configuration.
- Setup instructions are laid out sequentially in steps, including exploded views with detailed explanation for assembly.



Part Identification - Numbering

## Cleaning & Packing

- For Cleaning Metal, Plex, & Laminate Parts: Use a **MILD NON-ABRASIVE** cleanser and soft cloth/paper towel to clean all surfaces.
- Keep exhibit components away from heat and prolonged sun exposure.  
**Heat and UV exposure will warp and fade components.**
- Retain all provided Packing Materials. All provided packing materials are for ease of repacking & component protection.



Engaged Lock



# WARNING



DO NOT USE POWER TOOLS



ALL CONNECTIONS MUST BE TIGHTLY SECURED

## Disassembly

- For loss prevention, keep all knobs & connectors attached to extrusions during disassembly.

## Straight Connection

When assembling frame, first attach all **straight connectors**, then attach **corner connectors**.

- 1) Place extrusions end-to-end.
- 2) Loosen all knobs, then slide **straight connector** across the seam of extrusions.
- 3) Tighten all knobs to secure connection.



Slide connector across seam of extrusions.  
Tighten all knobs.



## Disassembly

- 1) Loosen all knobs.
- 2) Slide connectors off of one extrusion.
- 3) Tighten knobs to prevent loss during packing & shipping.

Keep straight connectors in groove of extrusion. Do not remove connectors during disassembly.

All knobs must be tightened securely to ensure a proper connection.

## Corner Connection

- 1) Loosen knobs, then slide vertical extrusions onto **corner connectors** of **lower** horizontal extrusion.
- 2) Slide **corner connectors** of **upper** horizontal extrusion into grooves of vertical extrusions.
- 3) Tighten all knobs to secure connection.

## Disassembly

- 1) Loosen knobs on vertical extrusions.
- 2) Slide the vertical extrusions off of **corner connectors** on lower and upper horizontal extrusions.



Slide verticals over lower connectors.

Then slide upper connectors into groove of verticals.

Tighten all knobs.



Adjust connectors if necessary to prevent gaps in connection.



COMPLETED ASSEMBLY

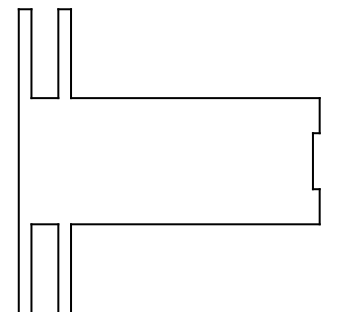

TSP49 Profile

All knobs must be tightened securely to ensure a proper connection.

### Top View of Each Level

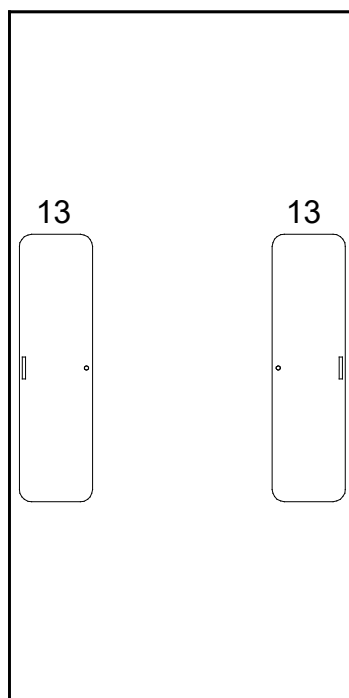

Level 1  
(Bottom level)

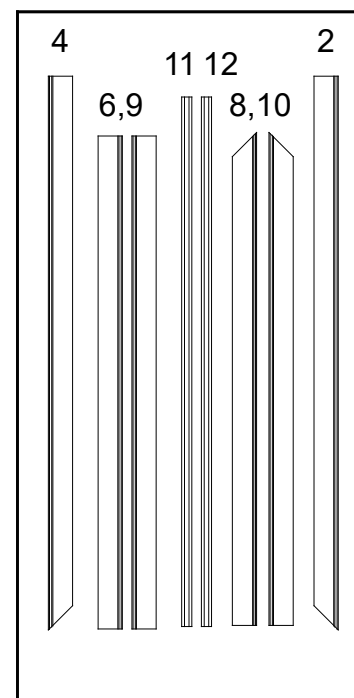

Level 2

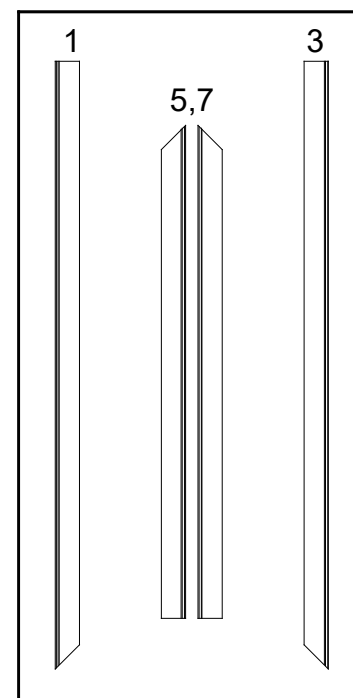

Level 3

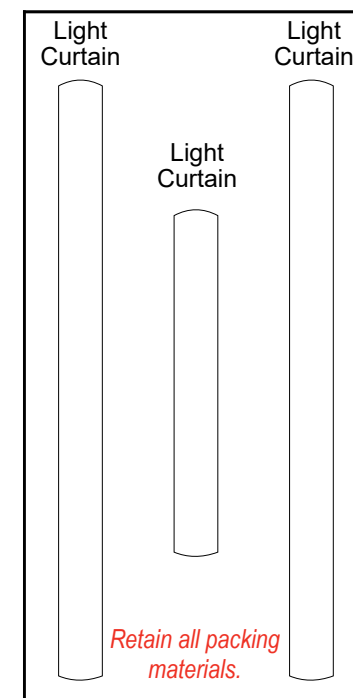

Level 4

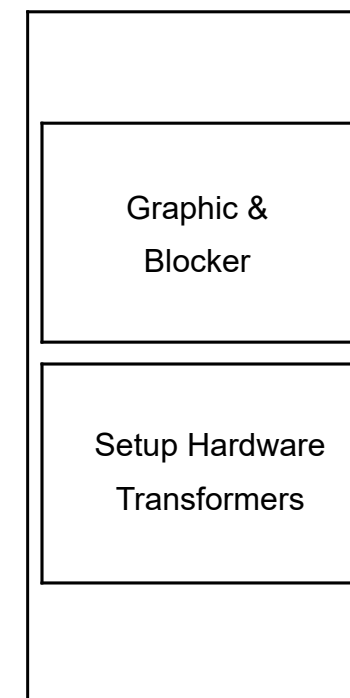

Level 4

Item	Qty.	Description
1	1	45"h TSP49 Vertical Extrusion
2	1	41"h TSP49 Vertical Extrusion
3	1	45"h TSP49 Vertical Extrusion
4	1	41"h TSP49 Vertical Extrusion
5	1	36.5"w TSP49 Horizontal Extrusion
6	1	36.5"w TSP49 Horizontal Extrusion
7	1	36.5"w TSP49 Horizontal Extrusion
8	1	36.5"w TSP49 Horizontal Extrusion
9	1	36.5"w TSP49 Horizontal Extrusion
10	1	36.5"w TSP49 Horizontal Extrusion
13	2	6" x 22" Base Plate w/ flange

Steps:

Refer to the [Tool-less Frame Assembly general information page](#).

- 1) Assemble vertical extrusions [1-2], [3-4] & horizontals [5-6-7], [8-9-10] together, using [Tool-less Spline Connector](#) labeled [X]. *Note: Hanging clips on horizontals must face back of frame.*
- 2) Connect vertical assemblies [1/2], [3/4] between horizontal assemblies [5/6/7], [8/9/10], using [Tool-less Corner Connectors](#) labeled [A].
- 3) Install Base Plates [13] & [14] to bottom corners of frame assembly as shown. See [Base Plate Attachment](#) detail.

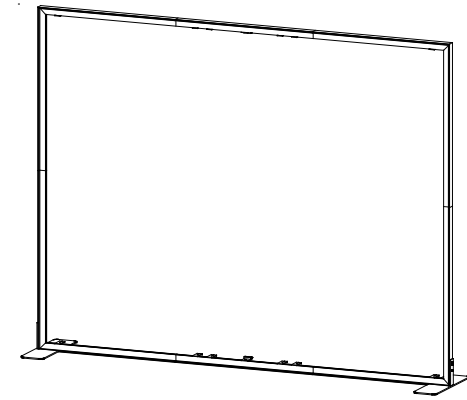

When assembled

Assemble frame flat on ground.

**\* Tool-less Spline Connector**

1. Place extrusions end-to-end.
2. Slide tool-less connectors across seam of extrusions.
3. Tighten all knobs to secure connection.

**\* Tool-less Corner Connector**

1. Slide extrusion onto Corner Connector.
2. Tighten all knobs to secure connection.

*Keep corner connectors attached to horizontal extrusions.*

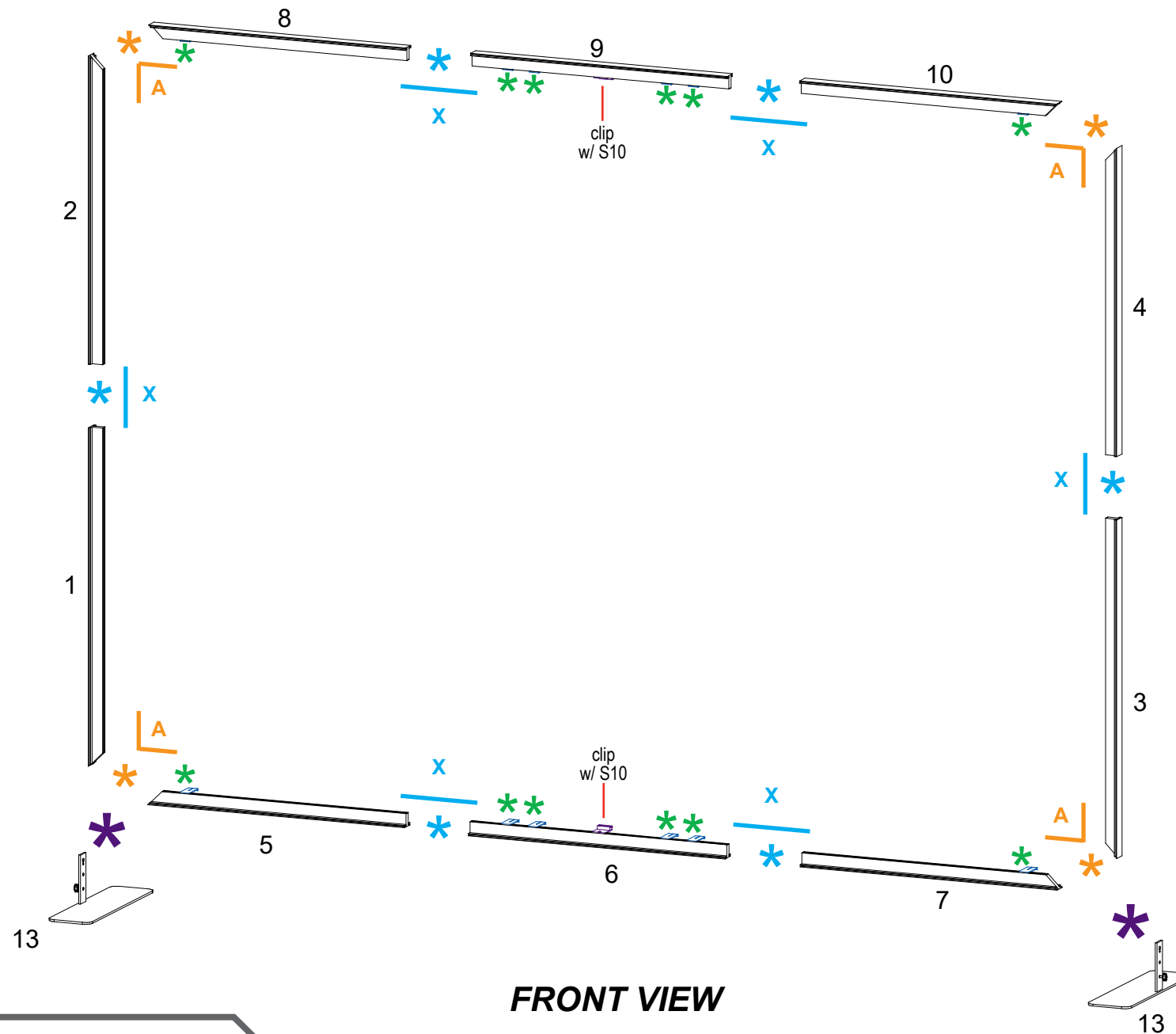

FRONT VIEW

**\* Hanging Clips** *Keep all clips attached to extrusions. DO NOT DISASSEMBLE*

Hanging clips are attached to horizontal extrusions using V4 connectors at locations shown.

**V4 Connector**  
Note: Center clip has custom V4 connector.

TOP VIEW

All Hanging Clips will face **back** of the frame.

**\* Base Plate Attachment**

- 1) Place key hole over bolt on panel & slide down.
- 2) Twist knob to secure connection.

Lattice Light Installation

**1** Rotate clips on top & bottom extrusions so that groove faces back of frame.

**2** Lift up lattice light curtain & insert ball chain into groove of upper clips  
*Lights should face front of booth.*

**3** Hook loops at bottom of light curtain over lower clips

Item	Qty.	Description
11	1	45.209"h Z45 Vertical Extrusion
12	1	37.209"h Z45 Vertical Extrusion
--	1	19.125"w x 86"h Lattice Light Curtain
--	2	38"w x 86"h Lattice Light Curtain

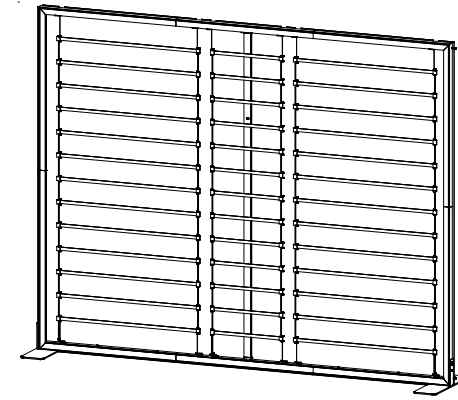

When assembled

Steps:

- 1) Install center Lattice Light curtain to back of frame.
- 2) Assemble vertical extrusions [11-12] together, using **Tool-less Spline Connector** labeled [X].
- 3) Connect vertical assembly [11/12] between S10 extrusions on lower & upper clips of frame, using **Connection Lock w/ Knob**.
- 4) Install remaining Lattice Light curtains to back of frame.
- 5) Connect power cords to lights as shown.

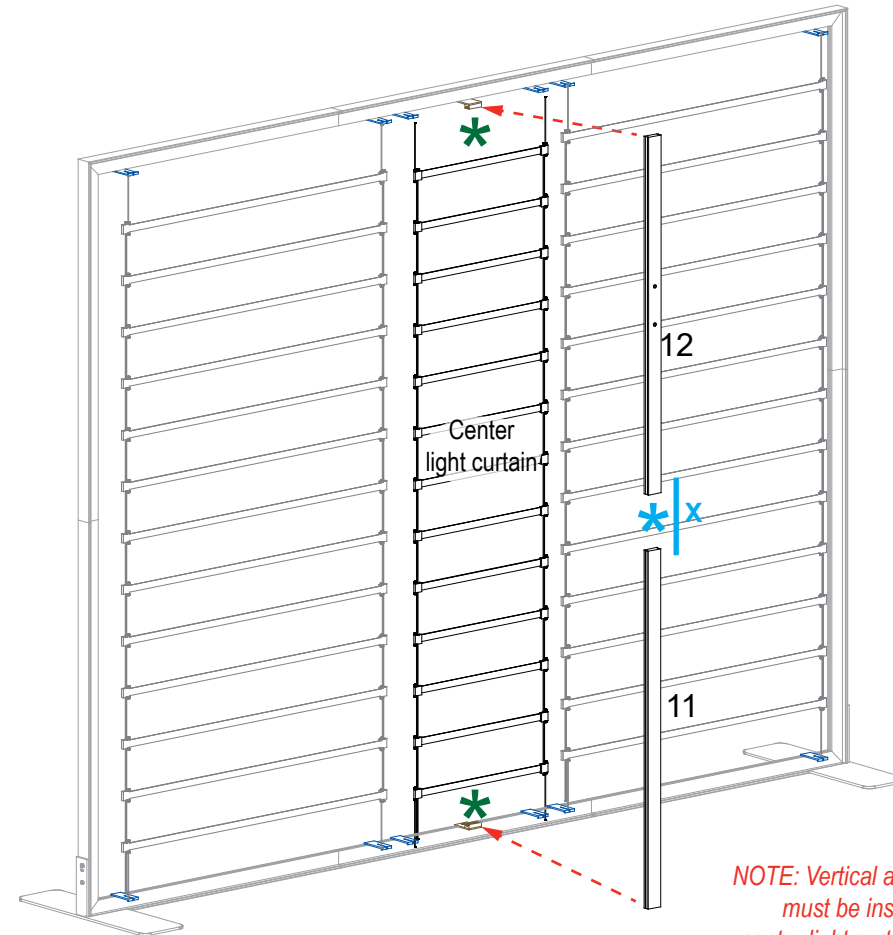
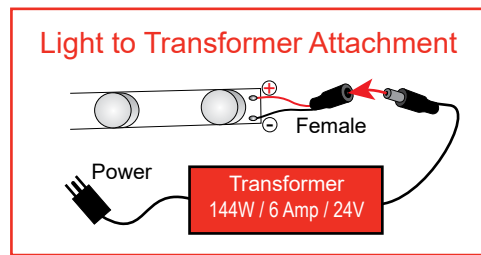
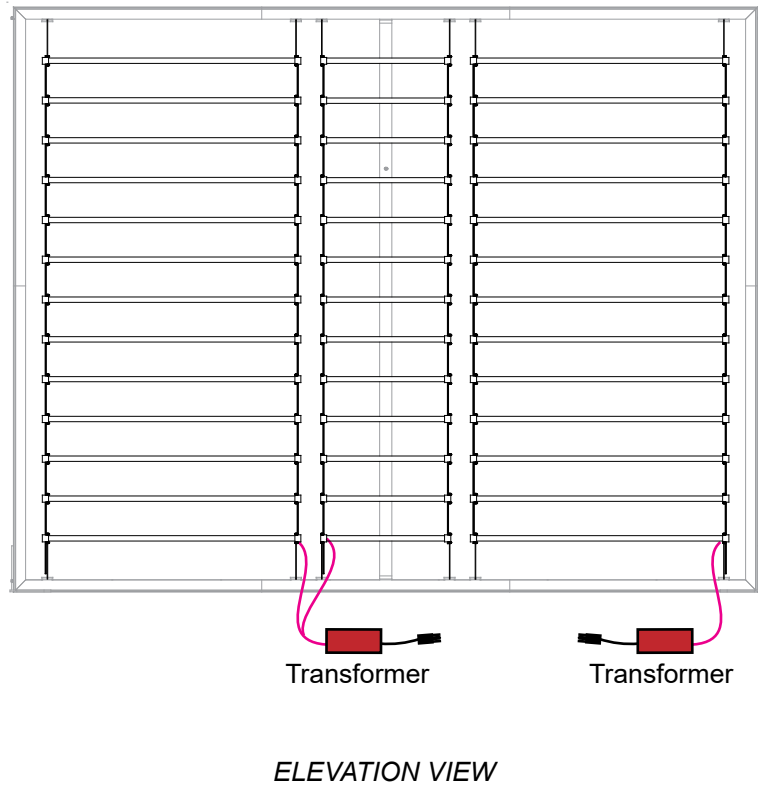

NOTE: Vertical assembly [11/12] must be installed after center light curtain is attached.

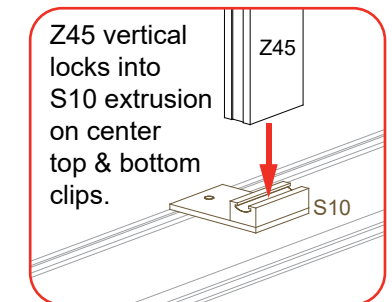

BACK VIEW

Light Blocker Attachment

1

Assemble top & bottom rods.

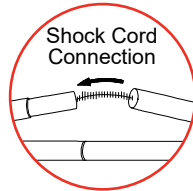
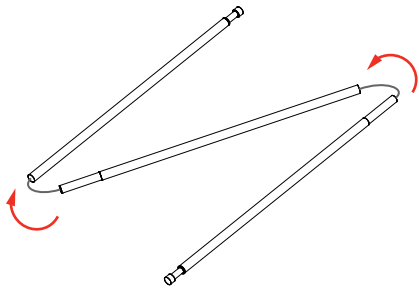

2

Insert rods through top & bottom pockets of light blocker.

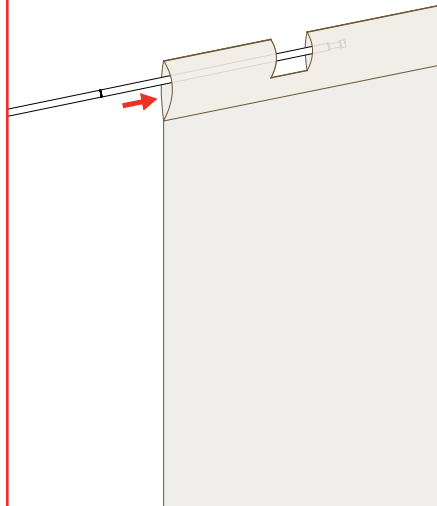

3

Lift up light blocker. Hook top rod over upper clips, then hook bottom rod over lower clips.

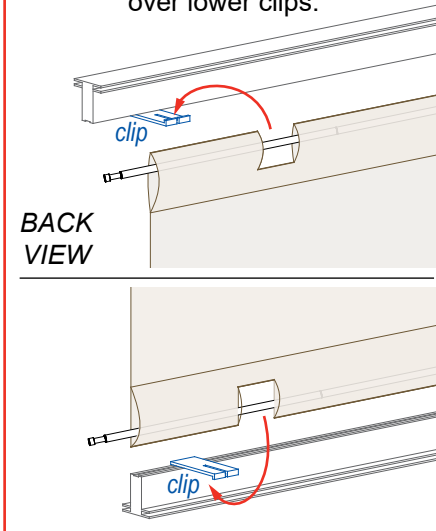

Item	Qty.	Description
--	2	Approx. 110"w x 5/16" collapsible rod
--	1	109.242"w x 85.843"h Light Blocker

Steps:

- 1) Assemble rods & insert into top & bottom pockets of light blocker as shown.
- 2) Hook rods over top & bottom clips on back of assembled frame to secure light blocker in place.

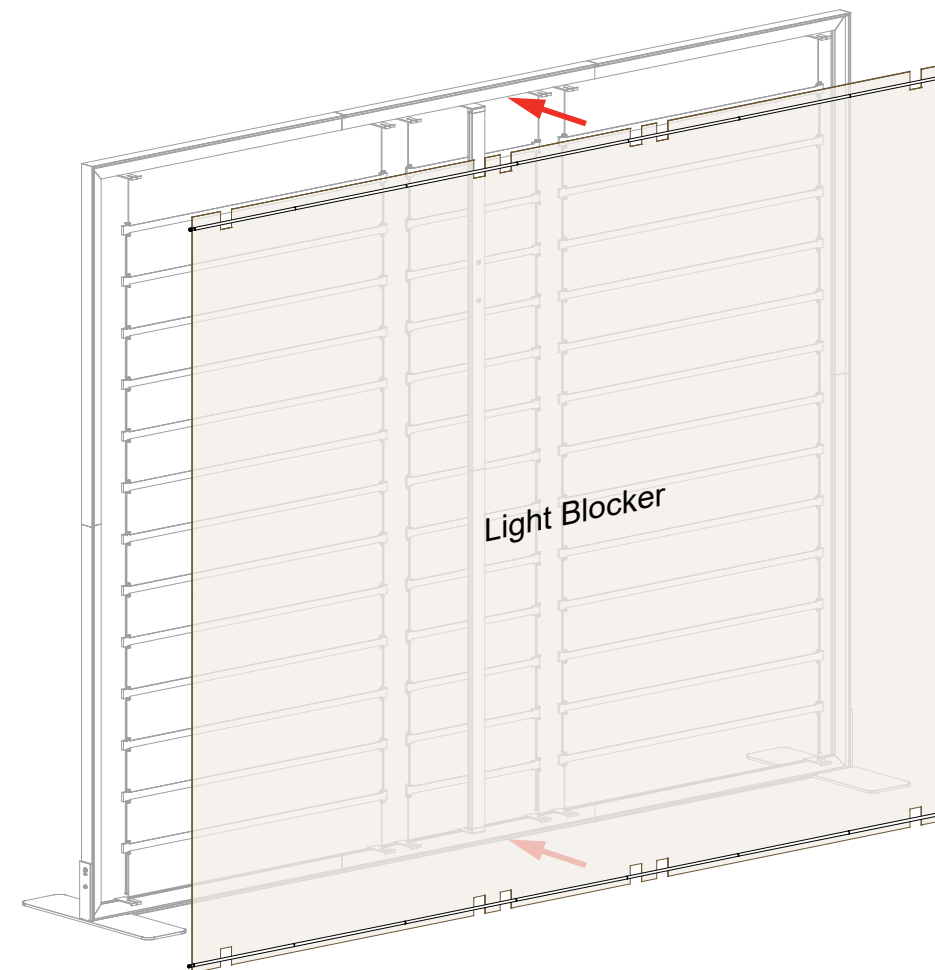

BACK VIEW



## SEG Graphic Installation

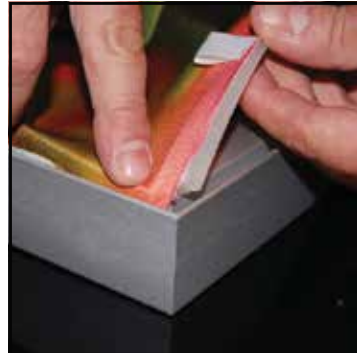
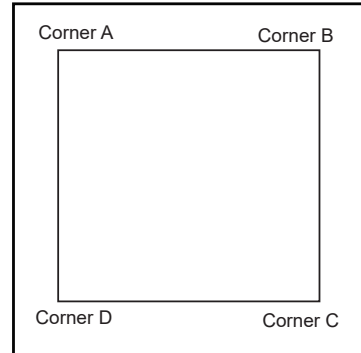

It is important to first insert graphic into each alternate corner, then to the sides of the frame. If this is not done, graphic will not fit into the frame correctly.

**Step 1**  
Insert corner A. Turn edge of graphic so silicon welt is perpendicular to face of graphic. Insert narrow side of welt with fabric to outside into the channel. Repeat for other side of this corner.



**Step 2**  
Repeat Step 1 for opposite corner C, then insert corner B, followed by corner D, to complete the installation of the corners.



**Step 3**  
Once all corners are inserted, press one silicon edge into channel from corners and work toward the center. Make sure welt is fully inserted into channel. Continue until all sides are done. Smooth out edges of graphic.

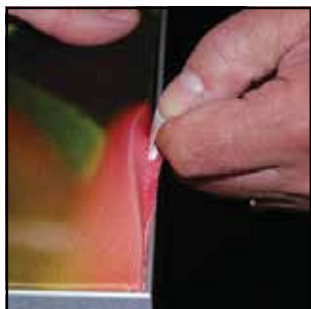

### Graphic Removal

To remove the graphic from the frame, locate the fabric pull tab. Gently pull up on the tab to remove the fabric.

Steps:  
1) Apply SEG Graphic to front of assembled frame.

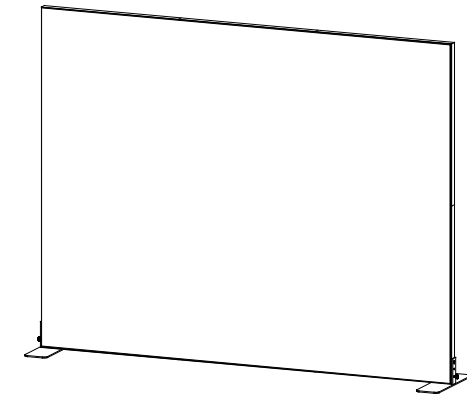

Completed Assembly

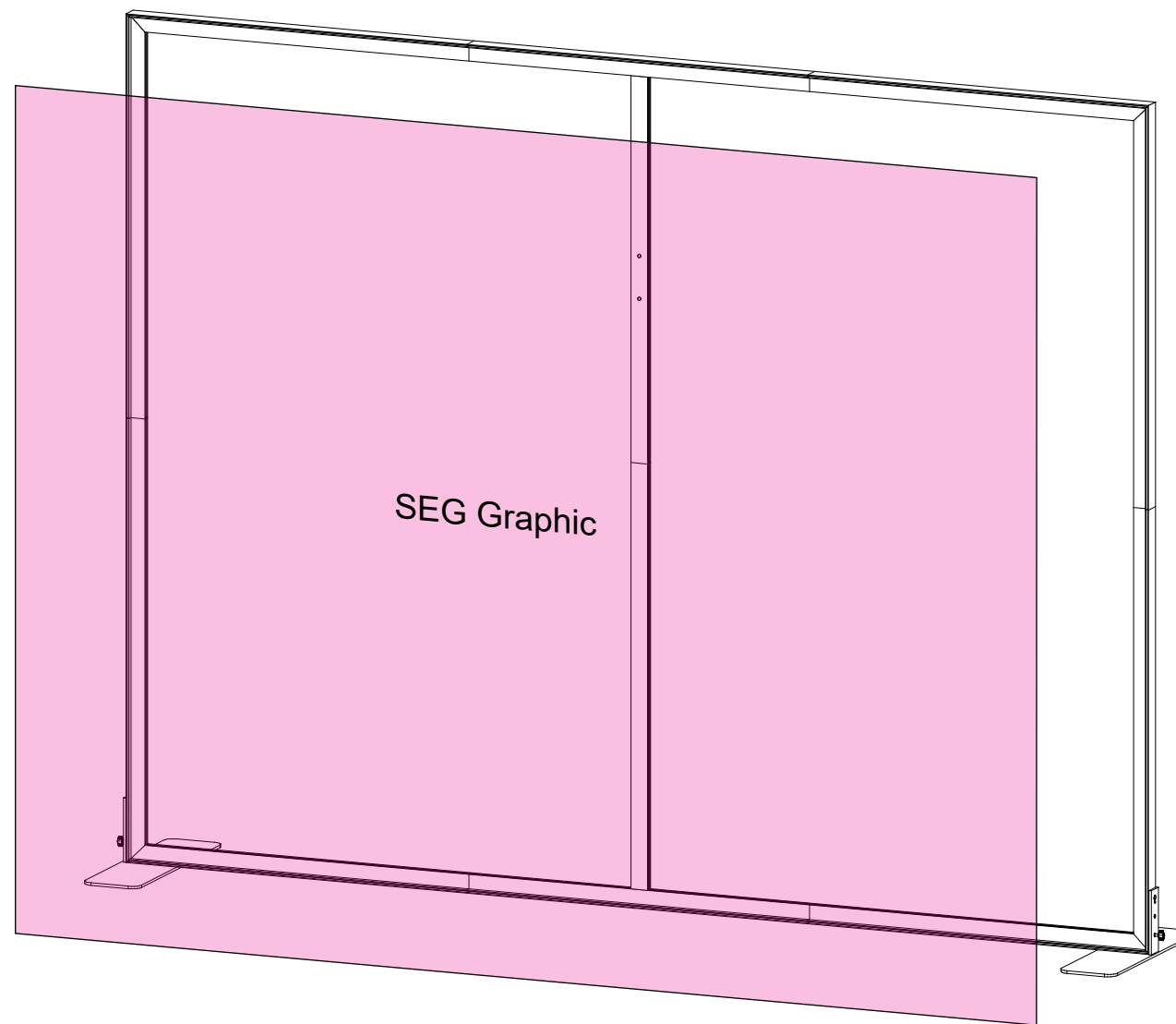

FRONT VIEW